



303 MESSNER DR. • WHEELING, IL • 60090
847-459-1460 • FAX 847-459-1569
WWW.LUND-INDUSTRIES.COM

Installation Instruction

ULTP4 & ULTP4-XL

Rev 12/30/10

Note: The ULTP4 hold-down clips & key lock are designed to securely hold the laptop in the mount and to deter theft, not prevent it. Lund Industries, Inc. recommends taking your laptop out of the vehicle when not in use.

The Lund Industries, Inc. ULTP4 & ULTP4-XL are universal computer mounts for virtually any notebook computer. The ULTP4 will accommodate computers anywhere from 8.25" to 13.38" wide, depths from 7" to 12.63", and a thickness of up to 2.44". The ULTP4-XL will accommodate computers anywhere from 11.25" to 16.38" wide, depths from 7" to 12.63", and a thickness of up to 2.44".

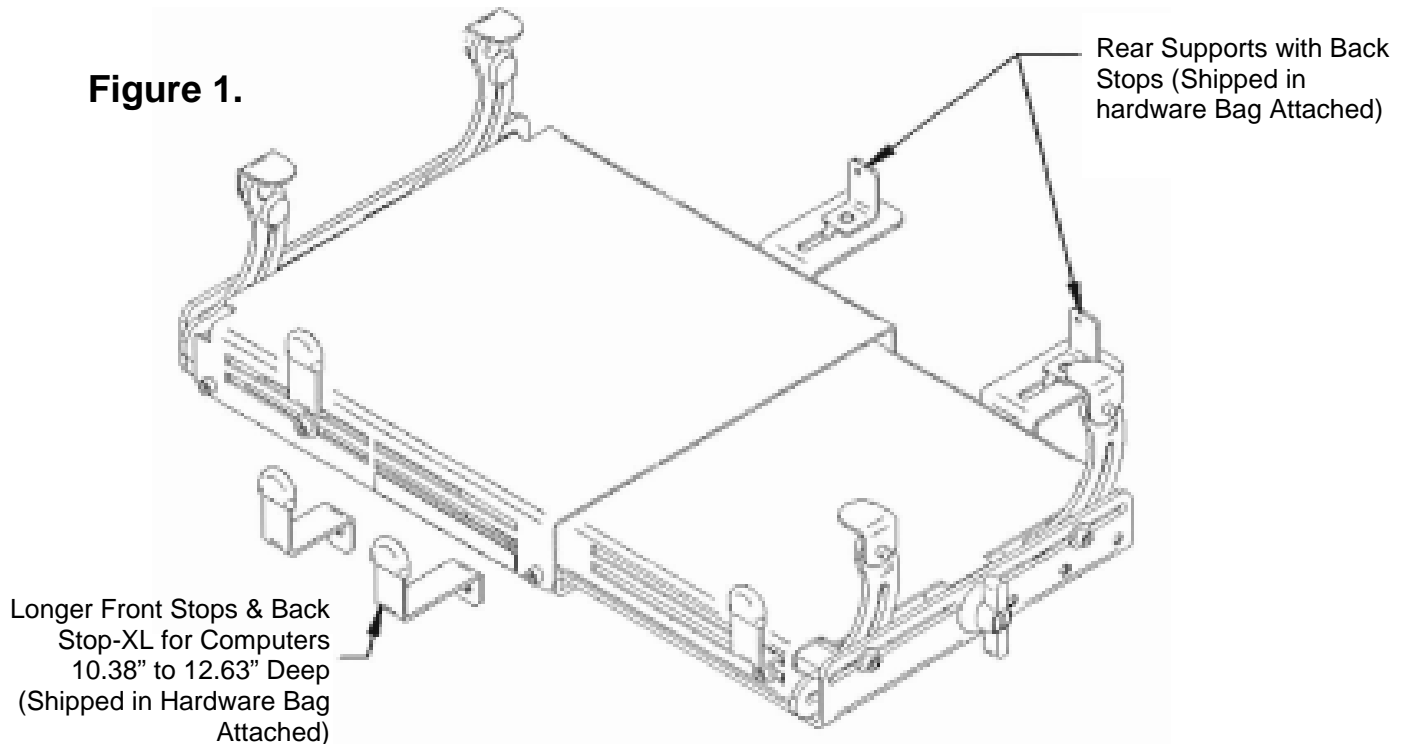

Assembly of the Rear Supports: See Figure 1.

1. Install the Rear Supports to the back side of the ULPT4 in the same manor that the Front Retainers are assembled. Insert the bottom flange of the rear support (the flange with the Pem Nut inserted into it) into one of the top slots. Rotate the bracket up so the top surface of the bracket is flush with the top surface of the ULTP4. The pem nut should now be visible through the lower slot.
2. Fasten the bracket in place with the #8-32unc x 3/8" long socket head cap screw and flat washer that were provided in hardware bag. Leave the screw loose to allow for final adjustment at a later time.

If you need assistance or have questions, call Lund Industries Inc. at 1-800-504-1460

Adjusting the ULTP4 for the computer: See Figure 2.

1. Loosen the adjustment screws which fasten the Hold-down Clips in place.
2. If the latch on the ULTP4 is locked, unlock the unit with the supplied keys. Unlatch the "Wing Turn" latch by rotating the lock 90 degrees counter clockwise so the "Wing Turn" is positioned in the vertical orientation as shown below.
3. Grab both sides of the ULTP4 and pull the unit apart to extend the ULTP4 to its widest extent.
4. Place the computer on top of the ULTP4. Slide the computer up tight against the Front Retainer and the Extended Front Retainer.
5. Slide the computer to the left side of the ULTP4 until it bumps up against the Hold-down Clips. Adjust the left side Hold-down Clips so the upper pivot tab will just clear the top of the computer and tighten in place. A snug fit is preferred. Make sure not to cover any ports on the computer that will be used.
6. Grab both sides of the ULTP4 and push the unit back together until the right side Hold-down Clips bump up against the computer. Adjust the right side Hold-down Clips in the same manner as you did the left side.
7. While pushing the unit together (compressing the computer between the hold-down clips) turn the "Wing Turn" latch 90 degrees clockwise. This will hold the unit in the compressed state.
8. Adjust the Rear Supports to the location which best fits your needs, and tighten in place.
9. Adjust the Back Stops so it prevents the computer from moving back. Make sure not to cover any ports on the computer that will be used.

Optional

10. Four vinyl caps have been placed in the hardware bag. These caps can be super glued in place on the Upper Pivot Tabs to help protect your computer. **Note:** By adding the tabs could prevent the computer screen from being able to fully close.

