



3175 MacARTHUR BLVD. • NORTHBROOK, IL • 60062
847-459-1460 • FAX 847-714-9443
www.lund-industries.com
www.data-carts.com

2020+ Ford Interceptor Utility
PASS Install Guide
P/N PASS-2-PIU20



DRIVERS SIDE



PASSENGER SIDE

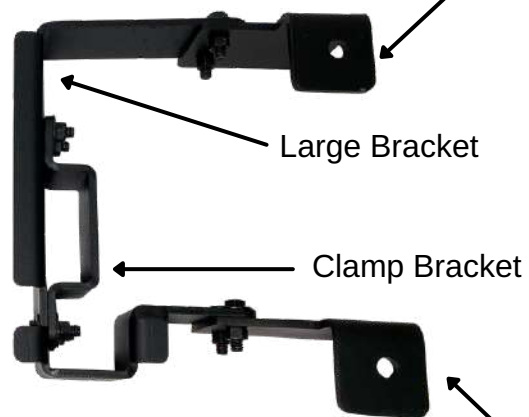

Upper Bracket

Large Bracket

Clamp Bracket

Lower Bracket

Always!

- Read all instructions before installing any Lund products.
- Check for obstructions (Wires, brake lines, fuel tank, etc.) before drilling any holes!
 - Use hardware provided with install kit

- Remove front fascia, upper and lower air deflectors. Use the fascia removal guide <http://lund-ind.com/PIU20-FASCIA> if you need help.
- Once fascia and deflectors are removed, install 2 large PASS brackets to the center of the aluminum bumper section. Push the brackets to the outside of the vehicle bumper as far as possible. Next attach the front clamp bracket with supplied 3/8-16 x 1 1/8" hex bolts as shown in **(Fig.1)**
- Fully tighten each large PASS bracket to vehicle bumper. Loosely add the upper and lower "L" brackets and test fit the PASS Bumper. Adjust brackets if necessary. **(Fig.2)**
- Remove PASS Bumper, Upper & Lower "L" Brackets.
- Trim upper and lower deflectors to fit around 2 large brackets. **(Fig.3&4)**

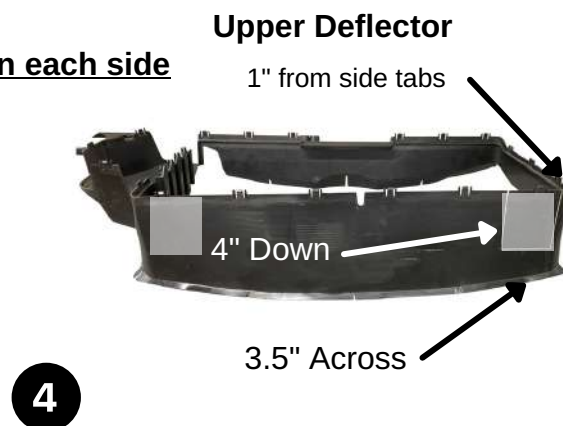
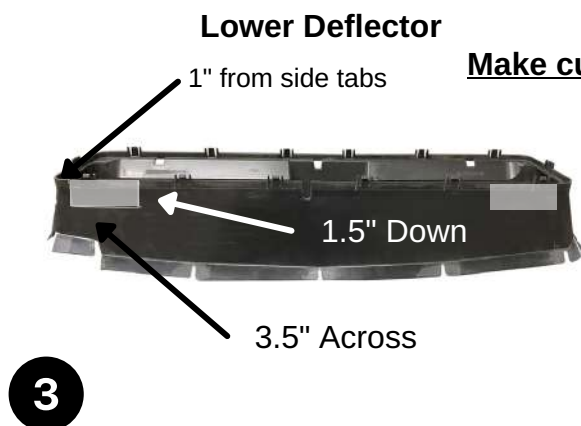
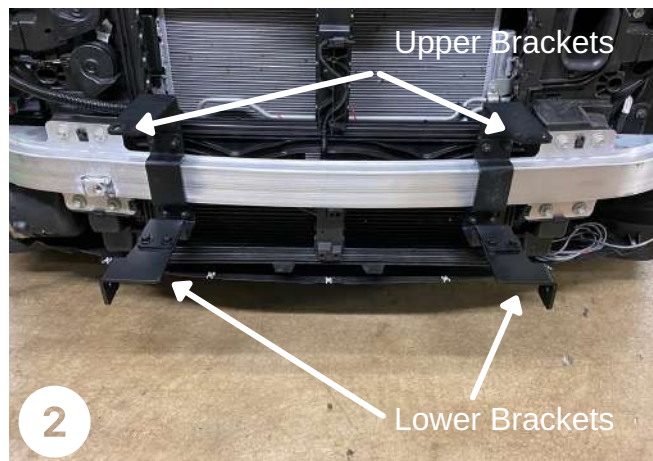
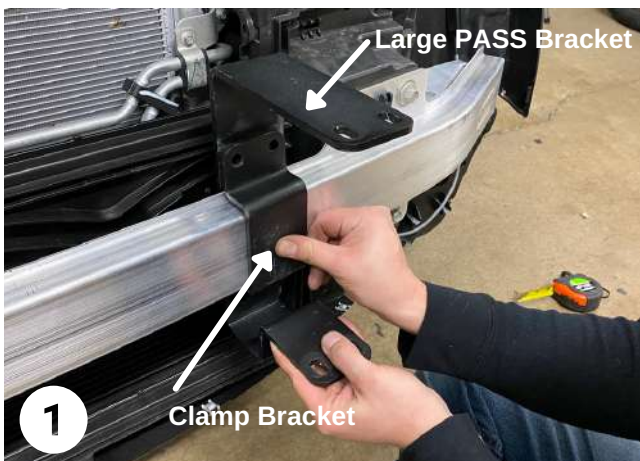

- Trim lower bumper fascia 1 1/4" inches so arms of the brackets can extrude through. **(Fig.5)**
- You are now ready to reinstall factory fascia, be ready to have an extra pair of hands to help you guide it back on and reinstall all factory hardware and tighten securely.
- Next reattach the upper and lower brackets to the PASS bumper arms with the supplied 3/8" hex bolts, washers and flange nuts. Leave loose for later adjustment. **(Fig.6)**
- Attach PASS Bumper to the PASS Brackets with supplied 3/8 hardware. Adjust and level PASS Bumper and tighten all hardware. **(Fig.7 & 8)**

