



303 MESSNER DR. • WHEELING, IL • 60090  
847-459-1460 • FAX 847-459-1569  
WWW.LUND-INDUSTRIES.COM

# FP-144

**Chevrolet: New Body Style**  
**1500/2500/3500 C/K (2007-Newer )**  
**Avalanche (2007-Newer)**  
**Tahoe (2007-Newer)**  
**Silverado (2007-Newer)**  
**Suburban (2007-Newer)**

**GMC: New Body Style**  
**Yukon/Yukon XL (2007-Newer)**  
**Sierra (2007-Newer)**

The purpose of this instruction sheet is to illustrate the manufacturer's recommended method of installation. The FP-144 is a vehicle base designed to fit the majority of '07 GM trucks and SUVs. The base is a discreet, no holes bored, one piece solution that installs in minutes.

1. Begin by removing the two nuts located on the front passenger's seat nearest the front of the vehicle. You will need to use an E-18 Inverted Torque Socket.
2. Next, loosen the bolts on the rear of the front passenger's seat which will require an E-14 Inverted Torque Socket. It is not necessary to remove these fasteners.
3. Lift up on the front of the seat and place the FP-144 on to the threaded studs using the primary mounting slots (see FIG. 1).
4. There are secondary mounting slots available if you wish to fasten the FP-144 to the floor with self-drilling screw or bolts (see FIG. 1).
5. This completes the installation of the FP-144. Add lower poles, upper poles, and other mounting hardware as desired.

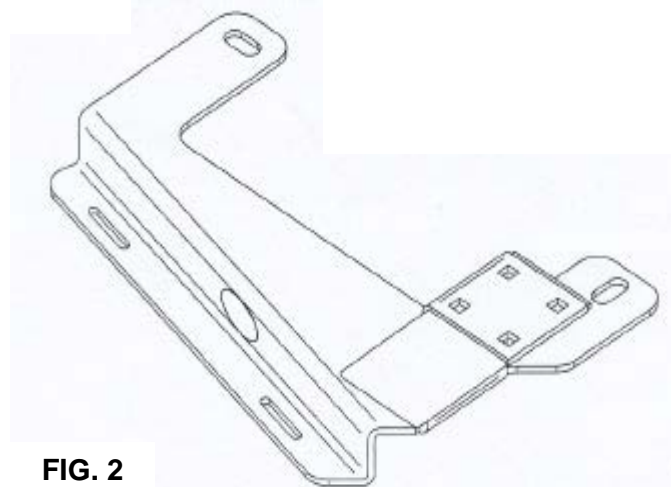
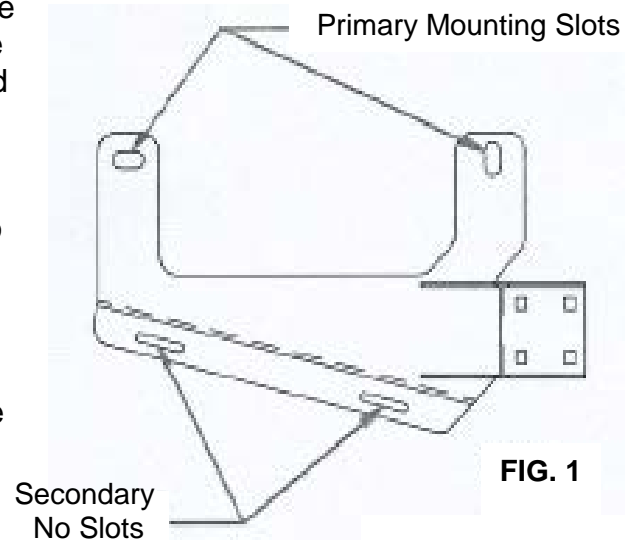

**\*\*An additional Offset Mounting Step**  
(Part # FP-STEP) is recommended to position the computer mounting system away from passenger leg space and out of the air bag zone. This may require the factory installed console to be removed.

#### Product Mounting Disclaimer

Lund Industries, Inc. is not liable under any theory of contract or tort law for any loss, damage, personal injury, special, incidental or consequential damages for personal injury or other damage of any nature arising directly or indirectly as a result of the improper installation or use of its products in vehicle or any other application. In order to safely install and use Lund Industries, Inc. products full consideration of vehicle occupants, vehicle systems (i.e., the location of fuel lines, brakes lines, electrical, drive train or other systems), air-bags and other safety equipment is required. Lund Industries, Inc. specifically disclaims any responsibility for the improper use or installation of its products not consistent with the original vehicle manufactures specifications and recommendations, Lund Industries, Inc. product instruction sheets.

Specialists in Emergency Vehicle Products Since 1978 Design, Manufacturing, Distribution & Installation