



# THE LOFT

STORAGE AND EQUIPMENT COMPARTMENT

*PATENT PENDING No. 62/397, 198*

## Installation Instructions

### Ford Police Interceptor Utility 2013+

### LOFT-FPIU-GV

#### Parts and Mounting Hardware:

<u>QTY</u>	<u>DESCRIPTION</u>	<u>PART NUMBER</u>
1	Main Frame Assembly	FPIU-LOFT-A1
1	Main Lid	FPIU-LOFT-L1
2	Universal Partition Mount "L" Bracket	FPIU-LOFT-BB
2	Wire Partition Back Plate	FPIU-LOFT-BB-1
2	D-Pillar Mount Bracket	FPIU-LOFT-FB-1
2	Frame Mount Bracket	FPIU-LOFT-FB-4
4	*Optional LED Light Mount Bracket	FPIU-LOFT-LB
8	5/16"-18 x 3/4" Allen Head Bolt	
32	5/16" Washer	
16	5/16"-18 Nylock Nut	
2	3/8"-16 x 1" Self-Threading Bolt	
2	3/8" Washer	
4	1/4"-20 x 1" Hex Head Bolt	
4	1/4"-20 Nylock Nut	
8	1/4"-20 Washer	

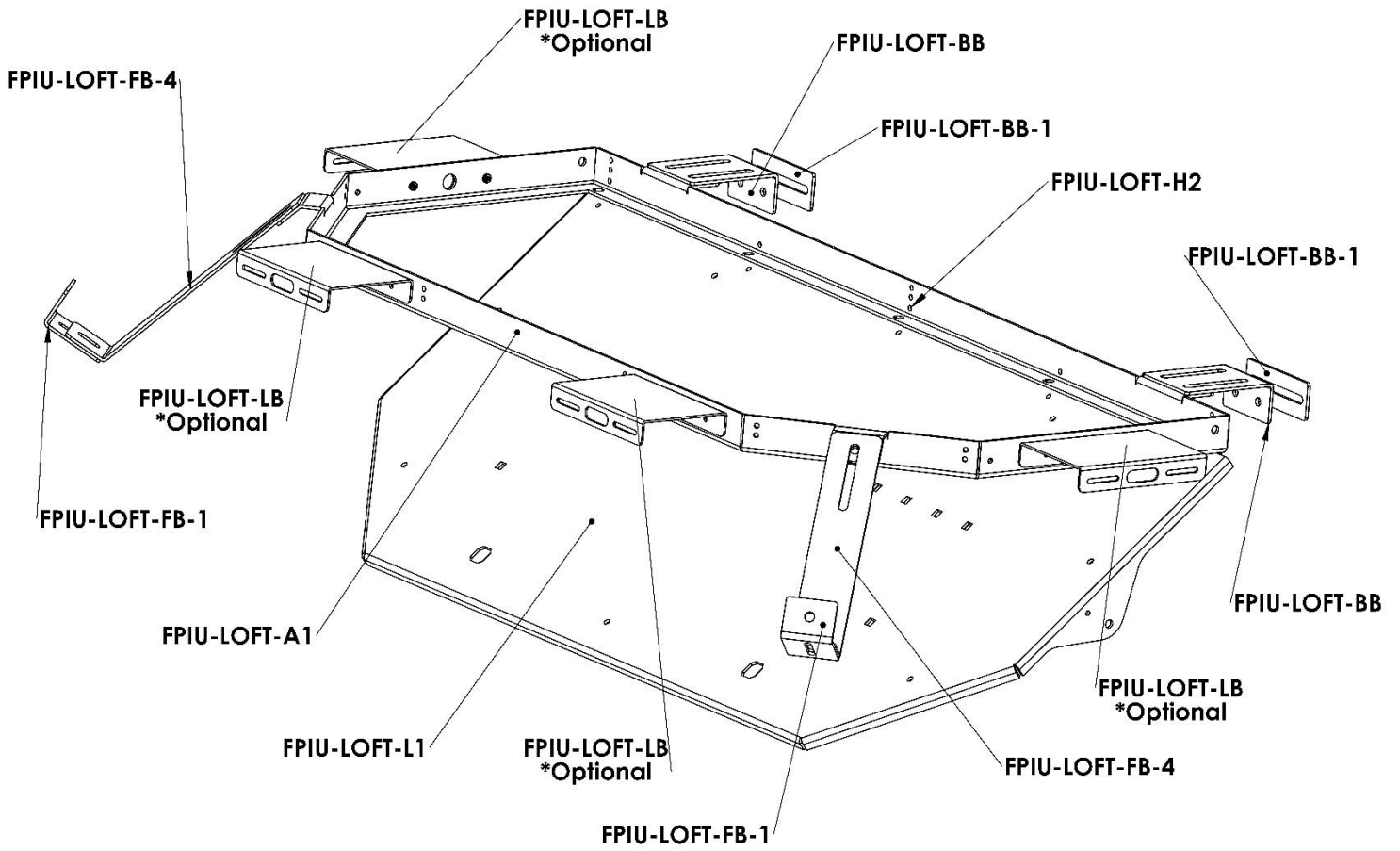

## LOFT PARTS KIT

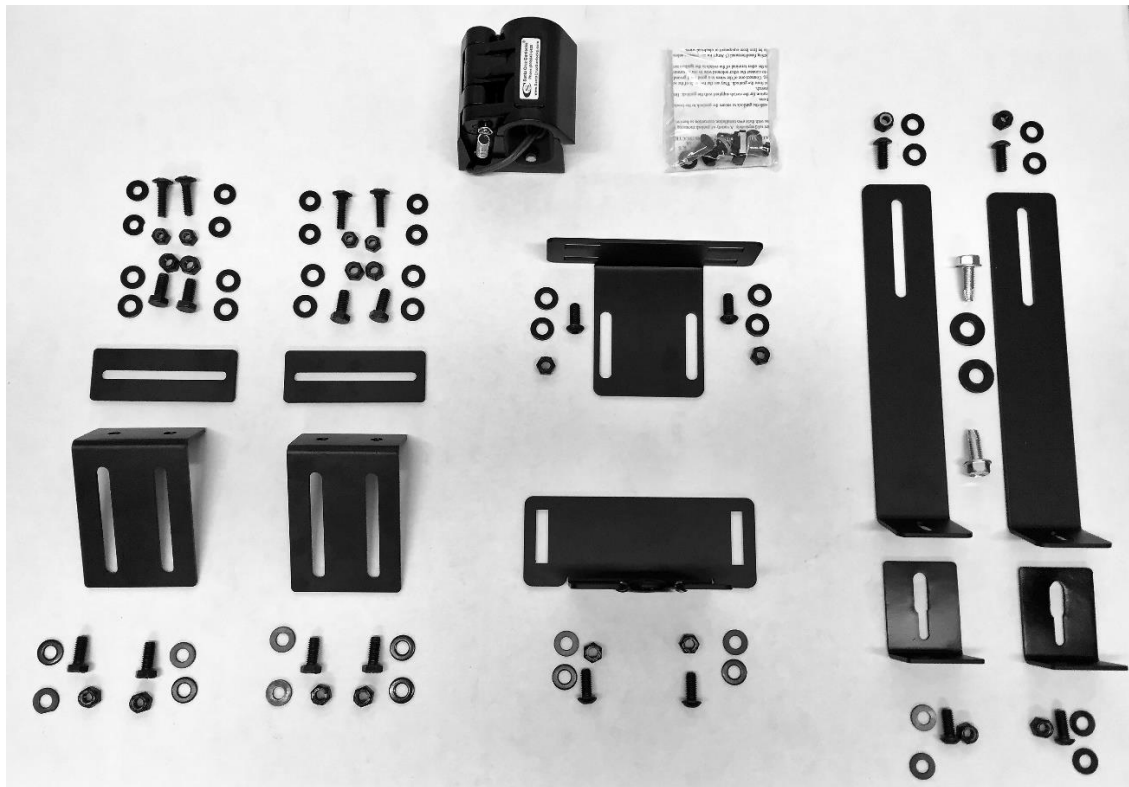

Rear Cargo Partition Cage needs to be installed behind second row seat prior to installation of LOFT. For non-partition mount option see separate instructions. Optional mount kit must be purchased. Order p/n LOFT-FPIU-NPKIT

It is recommended to preinstall gun lock bracket and muzzle containment bracket to loft tray. Also, add gun lock prewiring (timer / momentary switch). Timer, 12v power and momentary switch location are determined by end user.

If adding LED lights and brackets it is recommended to install and prewire them before installing LOFT. The small holes on the frame are to install wire ties as need for wire management. Order p/n LOFT-LEDBKT-4

## Installation Steps:



1. Remove upper rear D-Pillar trim panel on each side to expose factory 3<sup>rd</sup> row seat belt bolt holes. Use supplied Self Threading Bolts and washer to mount L-Bracket (FPIU-LOFT-FB-1) as shown in picture.



2. Reattach each trim panel. Loosely install Frame Mount Bracket (FPIU-LOFT-FB-4)

Use supplied 5/16"-18 x 3/4" Allen Head Bolts, nuts and washers.

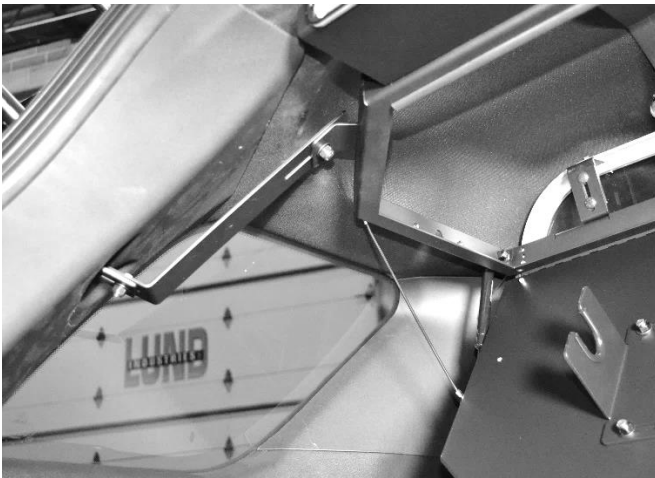

3. Two people are recommended for this step. A temporary support can be used to help position the LOFT.

Position LOFT Assembly in rear hatch area and attach the (2) rear brackets to the frame. Push frame up towards roof liner as high as possible. As shown in picture.

Use supplied 5/16"-18 x 3/4" Allen Head Bolts, nuts and washers.



4. Level the LOFT left to right and front to back. Be sure it is as close to the roof as possible and still fits installed Gun and or equipment.

Install the Universal Partition Mount L Bracket (FPIU-LOFT-BB) to the loft and the rear partition. There are many different cage manufacturers and partition options. Installer needs to determine the best position to attach LOFT brackets to rear partition. Drilling the cage framework or attaching through a wire screen are recommended.

Picture shown as an example of mounting to a wire screen Using supplied backing plate.

5. After fully tightening all hardware on mounting brackets and LOFT frame. Double check your level left to right and front to back. Adjust as necessary.
6. You can now finalize any wiring.

## Using the Loft:

1. (2) wing latches are used to secure the LOFT tray in the closed position. They are key lockable for added security. Open tray by turning wing latches.
2. Gun locks are electronic and have a key override. Position gun into lock and muzzle bracket and close lock tightly. Check to ensure that gun is secure. If gun lock sticks when trying to open push on gun lock door to relieve pressure on locking mechanism.

**Caution: Be sure to comply with all gun safety rules when storing a firearm. Never store a firearm with a round in the chamber.**

