



# THE LOFT

STORAGE AND EQUIPMENT COMPARTMENT

*PATENT PENDING No. 62/397, 198*

## Installation Instructions

### Dodge Durango

### LOFT-DUR-GV

#### Parts and Mounting Hardware:

<u>QTY</u>	<u>DESCRIPTION</u>	<u>PART NUMBER</u>
1	Main Frame Assembly	DUR-LOFT-A1
1	Main Lid	DUR-LOFT-L1
1	D-Pillar L -Bracket Left Hand Side	DUR-LOFT-RB-LH
1	D-Pillar L-Bracket Right Hand Side	DUR-LOFT-RB-RH
2	Cage Extension Bracket	DUR-LOFT-3
2	Universal Partition Mount "L" Bracket	DUR-LOFT-4
2	Wire Partition Back Plate	DUR-LOFT-BB-1
1	Rear Bulk Head	DUR-LOFT-RBH
14	5/16"-18 x 3/4" Allen Head Bolt	
28	5/16" Washer	
14	5/16"-18 Nylock Nut	
2	7/16"-20 Hex Head Seatbelt Bolt	
2	7/16" Washer	
2	1/4"-20 x 1" Flange Nuts	
2	10/32 x 3/8 bolts	

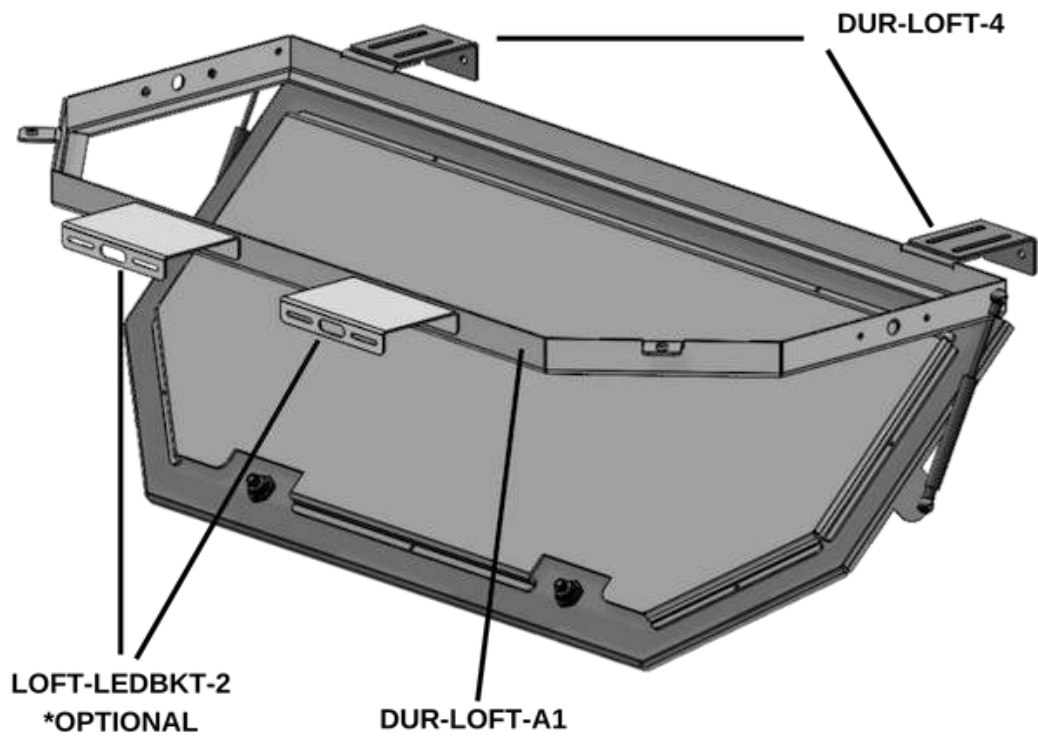

DUR-LOFT-RBH REAR HATCH BULKHEAD

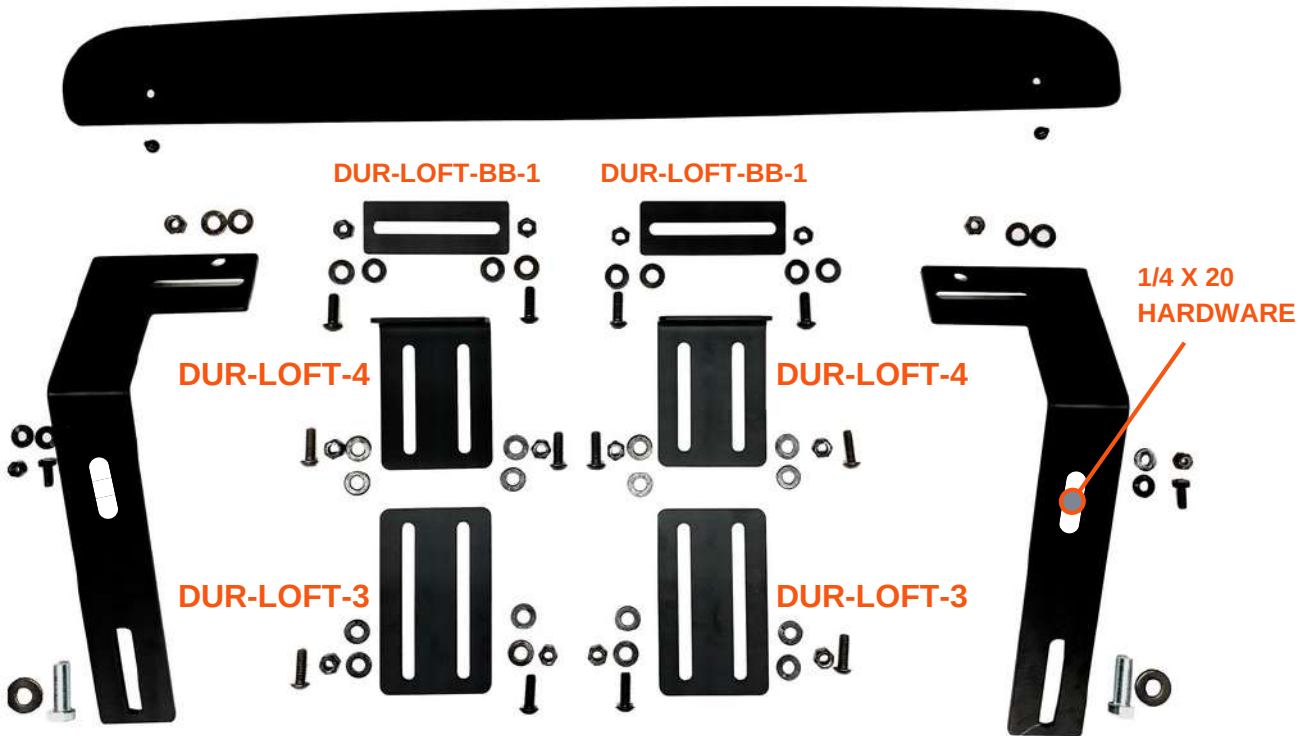

DUR-LOFT-RB-LH

DUR-LOFT-RB-RH



○ M4 RIFLE  
○ SHOTGUN

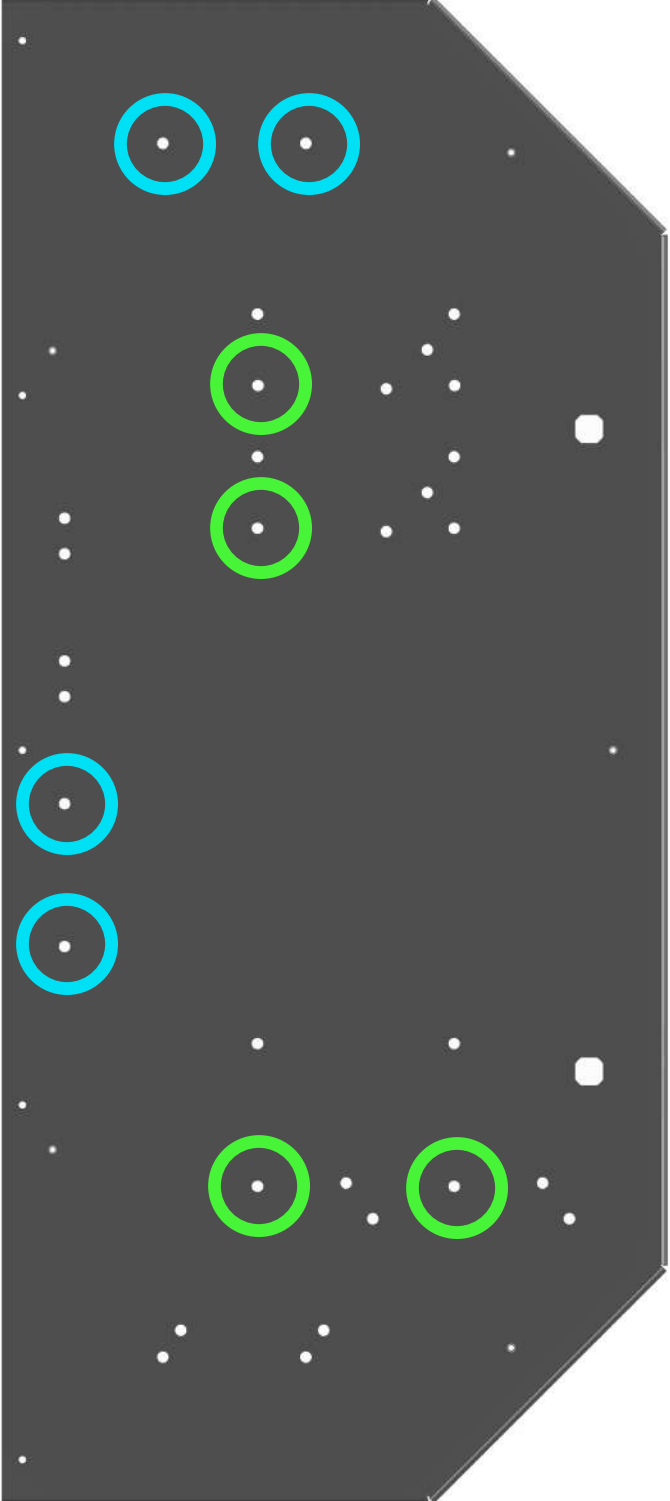

**CAUTION: FOR PASSENGER SAFETY, DO NOT USE 3<sup>RD</sup> ROW SEATING WITH THE LOFT INSTALLED.**

Rear Cargo Partition Cage needs to be installed behind second row seat prior to installation of LOFT. For non-partition mount option see separate instructions. Optional mount kit must be purchased. **Order p/n LOFT-DUR-NPKIT**

It is recommended to preinstall gun lock bracket and muzzle containment bracket to loft tray. Also, add gun lock rewiring (timer / momentary switch). **Timer, 12v power and momentary switch location are determined by end user.**

If adding LED lights and brackets it is recommended to install and prewire them before installing LOFT. The small holes on the frame are to install wire ties as need for wire management. **Order p/n LOFT-LEDBKT-2**

## **Installation Steps:**



1. Remove upper rear D-Pillar trim panel on each side to expose factory 3<sup>rd</sup> row seat belt bolt holes (remove 3<sup>rd</sup> row seatbelts if installed in vehicle). **For passenger safety, do not use 3<sup>rd</sup> row seating with LOFT installed.**

Use supplied 7/16-20 bolts & washers to mount rear Pillar Brackets. **(DUR-LOFT-RB-LH/RH).**

Push brackets up tightly to roof liner. Tighten bolts securely as shown in picture. **Caution: Be sure airbag & wires are out of the way.** Test fit factory D-Pillar Panel. Trim upper edge to fit around bracket as needed. Set aside until later step.



2. ***Two people are recommended for this step. A temporary support can also be used to help position the LOFT.***

Position LOFT Assembly in rear hatch area and attach the (2) rear brackets to the frame as shown in picture.

Use supplied 5/16"-18 x 3/4" Hex Head Bolts, nyloc nuts and washers. Tighten hardware.



3. Install the Universal Partition Mount L Bracket (**DUR-LOFT-4**) to the loft and the rear cargo partition.

***\*\*There are many different cage manufacturers and partition options. Installer needs to determine the best position to attach LOFT brackets to rear partition.***

Drilling the cage framework or attaching through a wire screen are recommended. Pictures shown are examples of mounting to a wire screen. A supplied backing plate (**DUR-LOFT-BB-1**) can be used to reinforce the mounting brackets.

Bracket (**DUR-LOFT-3**) can be used to lengthen the mounting bracket if need be.



Level the LOFT left to right and front to back. **Be sure it is as close to the roof as possible and still fits installed Gun and or equipment.**

4. Fully tighten all hardware on mounting brackets and LOFT frame. Double check your level left to right and front to back. Adjust as necessary.
5. Drill and add a 1/4" - 20 Bolt, nut and washers to the middle slot in the D-Pillar Brackets. **(DUR-LOFT-LH/RH) for added support of the LOFT.** Reinstall factory D-Pillar Panels
6. Using supplied 10-32 Screws, Secure rear bulkhead and Finalize any wiring.

## Using the Loft:

1. (2) wing latches are used to secure the LOFT tray in the closed position. They are key lockable for added security. Open tray by turning wing latches.
2. Gun locks are electronic and have a key override. Position gun into lock and muzzle bracket and close lock tightly. Check to ensure that gun is secure. If gun lock sticks when trying to open push on gun lock door to relieve pressure on locking mechanism.

**Caution: Be sure to comply with all gun safety rules when storing a firearm. Never store a firearm with a round in the chamber.**

